

Belt Replacement Instructions For TranzSporter Platform Hoists “Non Quick Change” Models

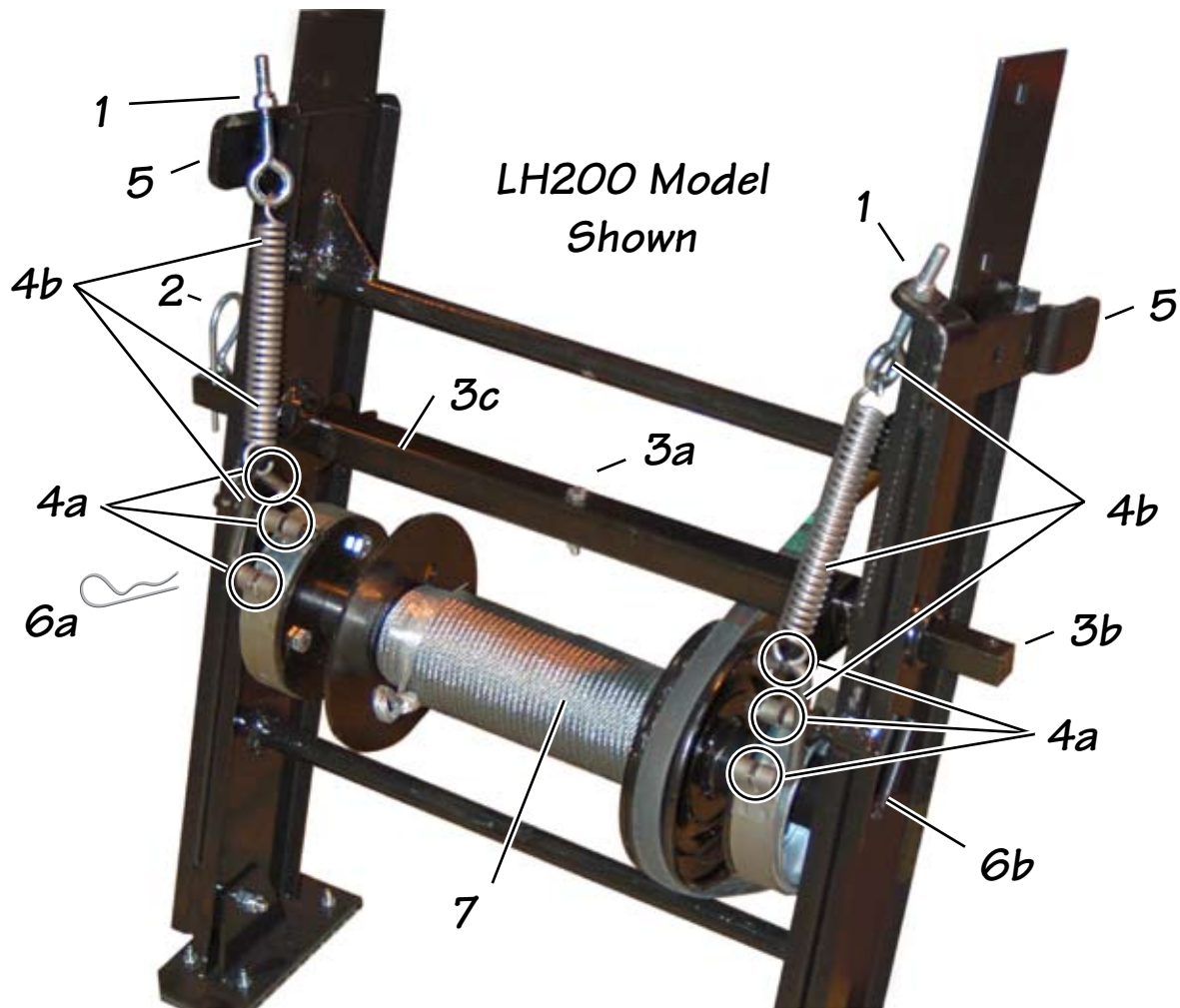

1. Scribe or mark the location of the nut for correct tensioning after re-assembly. Remove eye bolt by holding with a screw driver to keep it from spinning, remove the nut (#1).
2. Remove cotter pin on brake control shaft (#2).
3. Take nut and bolt out of the brake control shaft and brake control weldment (#3a). Slide out the brake control shaft (#3b) and remove the brake control weldment (#3c).
4. Remove small cotter pins on linkage and brake strap (3 pins per side, #4a). Remove spring from eye bolt, remove brake linkage from the strap brake (#4b). Remove strap brake. Repeat for the other side (except for LH2000 models).
5. On LH2000 (4' Aluminum Base Section) remove the left and right carriage support brackets and spacers (#5, see photo on page 2).

Belt Replacement Instructions For TranzSporter Platform Hoists “Non Quick Change” Models

- 6 Remove cotter pin on the cable drum shaft (6a) and slide out the cable drum shaft (#6b).
- 7 Remove cable drum by twisting sideways out from the frame.
8. Replace belt or bearings if needed.

Reassembly:

9. On the LH2000 (4' Aluminum Base Section) make sure that the new belt is placed in the “v” of the cable drum sheave prior to assembling the hoist back together.
10. With the new belt placed over the cable drum assembly, lift the drum assembly into position.
11. Push the cable drum shaft back through the base section and cable drum and replace the cotter pin the end.
12. Replace the left and right carriage stops with spacers (LH2000 only).
13. Replace brake control weldment and shaft, replace bolt and nut (3a, 3b, 3c).
14. Replace the eye bolt and nut and attach loosely to the carriage lock down bar (#1).
15. Slide the strap brake over the drum brake, repeat on other side if needed.
16. Lift/replace the spring and brake linkage (#4b) into the eye bolt (#4b). Replace the small cotter pins in the linkage, and strap brake (4a) repeat for other side.
17. Holding the eye bolt with a screw driver to keep it from spinning, tighten the nut to the scribed/marked position on the eye bolt, or until the spring is properly tensioned.



*Carriage stop
with spacers
(LH2000)*